



RFID KIT USER GUIDE

For printer models:

GL 4xxe Series



Read this User Guide before and during the operation of the above accessory. Keep this Guide handy for future reference.

9001173A

1 General

Important information

This quick guide provides important information on how to setup your new SATO product.

Be sure to read this quick guide thoroughly before using this printer. It is an integral part of the product and should be kept in the immediate vicinity of the device and available to the operating staff.

Limitation of liability

All information in this manual have been compiled under due consideration of federal standards and regulations.

The manufacturer will not be held liable for damage resulting from:

- Disregarding these instructions
- Unintended use of the printer
- Unauthorized technical modifications
- Use of unapproved spare parts
- Use of unapproved consumables

FCC WARNING

Changes or modifications not expressly approved by the party responsible for compliance could void the user's authority to operate the equipment.

NOTICE

This equipment has been tested and found to comply with the limits for a Class B digital device, pursuant to part 15 of the FCC Rules. These limits are designed to provide reasonable protection against harmful interference in a residential installation.

This equipment generates, uses and can radiate radio frequency energy and, if not installed and used in accordance with the instructions, may cause harmful interference to radio communications. However, there is no guarantee that interference will not occur in a particular installation.

1.2 Explanation of symbols

This instruction manual uses various warning icons to help you understand the safe operation of your printer. Explanations of the icons are below.



WARNING!

Indicates neglectful or erroneous use may cause irreparable damage to the product, serious injury to the operator, or worse.



CAUTION!

Indicates a specific point where caution should be used. The graphic within the triangle will indicate the specific issue, i.e.; the sign on the left indicates a caution for potential electrical shock.



CAUTION!

Indicates a potentially hazardous situation which, if not avoided, may result in damage to your product or host equipment.



NOTE!

Emphasizes useful tips or recommendations for efficient and smooth operation of your printer.

1.3 Contact and Document Information

For SATO office locations worldwide. please visit www.satoworldwide.com

Version: GBS-GL4xe-01rA-13-06-07-RFKUG © Copyright 1994 – 2007

All rights reserved. No part of this document may be reproduced or issued to third parties in any form whatsoever without the express permission of SATO. The materials in this document are provided for general information and are subject to change without notice. SATO assumes no responsibilities for any errors that may appear.

Overview

This User Manual describes the operation and programming procedures for RFID smart labels (with embedded RFID tags) on the SATO GL4xxe series printers fitted with the RFID Kit.

By incorporating RFID commands into the SATO® Basic Programming Language (SBPL) programs as described herein, users can produce smart labels to take advantage of the power of RFID technology.

This manual is organized as follows:

1. Introduction to the RFID configuration options in the GL4xxe series printer firmware
2. RFID Command Specifications
3. GL4xxe Coupler Design
4. Error Messages and Troubleshooting

1. Introduction to the RFID configuration options

RFID CONTROL Menu (GL4xxe Series)

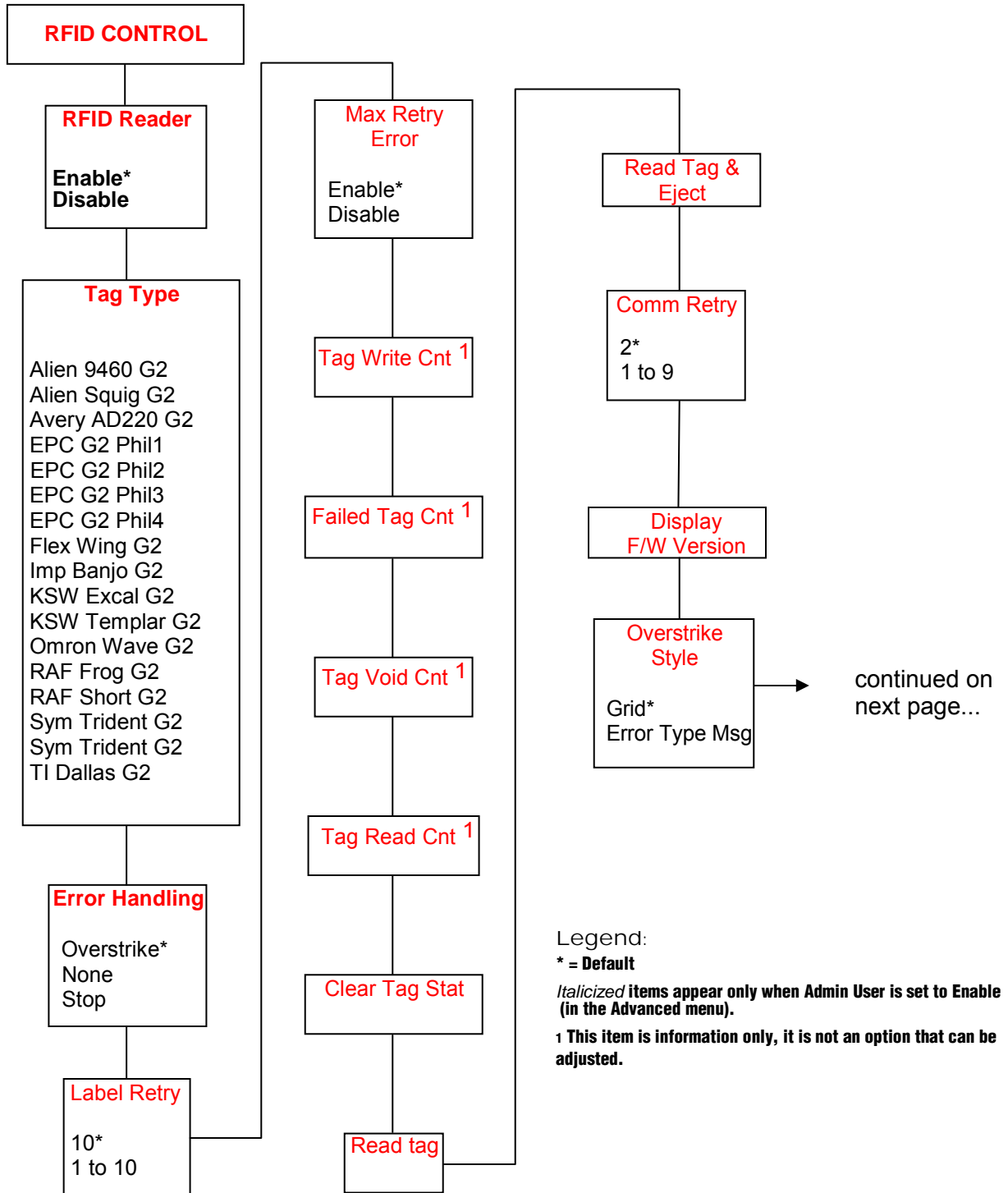

...continued from previous page

RFID CONTROL

Custom Setting	
Custom Tag Duplicate*	Tag Class Class 1*
Disable	GEN 2
Enable	Class 0
Write Power 6*	Class 0+
1 to 20	Class 1.19
Read Power 5*	Class Zuma
1 to 20	Read Tries 2*
EPC Byte Length 12*	1 to 10, infinite
8 to 32	Write Tries 9*
EPC Address 0*	RFID Calibrate To Run Press [∞]
0 to 32	Tag Position 0.0 mm*
USR Byte Length 0*	-13 to 127 mm
0 to 32	Scan Start Pos 0.0 mm*
USR Address 0*	0.0 to 127 mm
0 to 32	Scan Length 76 mm*
TID Byte Length 8*	0.0 to 127 mm
0 to 8	Cal Min Power 1*
TID Address 2*	1 to 20
0 to 32	Cal Max Power 20*
Block Write Len 8*	1 to 20
0 to 32	

Notes:

* = Default.

Italicized items appear only when Admin User is set to Enable (in the PRINTER SETUP menu).

Non-RFID Warning

Disable*
Enable

Introduction to the RFID configuration options

RFID Menu Items (GL4xxe)

RFID Reader

This menu item enables or disables the RFID encoder. The default is **Enable**.

Tag Type

This menu item selects the tag type for use. See Table 3 for supported tag types listed in alphabetical order. Other types may be added in the future.

Table 3. Supported RFID Tag Types (GL4xxe)

Tag Name	Bits	Protocol	Tag Class	Menu Selection
Alien Gen 2 Omni-Squiggle	96	Class 1, Gen 2	Gen 2	Alien 9460 G2
Alien Gen 2 Squiggle	96	Class 1, Gen 2	Gen 2	Alien Squig G2
Avery AD-220 (aka Runway)	96	Class 1, Gen 2	Gen 2	Avery AD220 G2
Generic Philips (coupler yellow)	96	Class 1, Gen 2	Gen 2	EPC G2 Phil1
Generic Philips (coupler orange)	96	Class 1, Gen 2	Gen 2	EPC G2 Phil2
Generic Philips (coupler red)	96	Class 1, Gen 2	Gen 2	EPC G2 Phil3
Generic Philips (coupler blue)	96	Class 1, Gen 2	Gen 2	EPC G2 Phil4
Impinj Gen 2 Banjo	96	Class 1, Gen 2	Gen 2	Imp Banjo G2

Table 3. Supported RFID Tag Types (GL4xxe)

Tag Name	Bits	Protocol	Tag Class	Menu Selection
KSW Gen 2 Excalibur	96	Class 1, Gen 2	Gen 2	KSW Excal G2
KSW Gen 2 Templar	96	Class 1, Gen 2	Gen 2	KSW Templar G2
Omron Gen 2 Wave	96	Class 1, Gen 2	Gen 2	Omron Wave G2
Rafsec Gen 2 Frog (3000790)	96	Class 1, Gen 2	Gen 2	RAF Frog G2
Rafsec Short Dipole (OneTenna)	96	Class 1, Gen 2	Gen 2	RAF Short G2
RF IDentics Gen 2 Flex Wing	96	Class 1, Gen 2	Gen 2	Flex Wing G2
Symbol Gen 2 Four T	96	Class 1, Gen 2	Gen 2	Sym 4T G2
Symbol Gen 2 Trident	96	Class 1, Gen 2	Gen 2	Sym Trident G2
TI Gen 2 Dallas	96	Class 1, Gen 2	Gen 2	TI Dallas G2

Label Retry

NOTE: Label Retry only applies when the Error Handling mode is set to Overstrike.

This menu item selects the number of label retries that the RFID encoder will attempt before declaring a fault. This may indicate a problem with the RFID encoder, the coupler assembly, the printer setup, or the label stock. The default is 10 retries.

Introduction to the RFID configuration options

Tag Write Cnt

Displays the number of tags attempted to be written since the last Clear Tag Stat operation was initiated. (See “Clear Tag Stat”.)

Failed Tag Cnt

Displays on the LCD the number of failed tag write attempts since the last Clear Tag Stat operation has been initiated. (See “Clear Tag Stat”)

Tag Void Cnt

Always displays 0 unless the RFID encoder is used with an attached Online Barcode Validator (OBV). When used with a validator, Tag Void Cnt represents how many valid RFID tags were overstruck due to bad barcode scanning.

Tag Read Cnt

This menu item displays the number of tags read since the last Clear Tag Stat. (See “Clear Tag Stat”)

Non-RFID Warning

When set to Enable, this option causes the printer to check to make sure that non-RFID jobs are not being printed on RFID labels (to prevent RFID labels from being wasted).

If RFID labels are installed in the printer, and a job is printed with at least one form that contains no RFID commands, a fault will be declared and the data for the forms that contain no RFID commands will be absorbed.

The default is **Disable**.

Introduction to the RFID configuration options

Admin User Menu Items (GL4xxe)

These menu items are visible only when the **Admin User** option is set to **Enable** in the **Advanced menu**. (See the GL408/412e Operator's Manual.)

IMPORTANT

Admin User menu items should only be used by authorized personnel.

Error Handling

This menu item selects the error handling mode for RFID failures. The default is Overstrike.

In Overstrike mode, each failed label prints with the Overstrike pattern and the form retries on a new label until the Label Retry count is exhausted. Whether or not an error message will display (or the failed label will reprint) depends upon the **Max Retry Error** setting.

In None mode, no specific action is taken when a tag fails to be programmed.

In Stop mode, when a tag fails to be programmed, the printer will halt and display the error message "**RFID Error: Check Media.**" The label is discarded and reprinting of the label (if desired) must be initiated from the host. When the error is cleared, the label with the failed tag moves forward until the next label is in position to be printed.

Max Retry Error

Enables or disables Max Retry Error. If it is set to **Disable**, errors are not declared and the print content for the current label is discarded. The default is **Enable**.

Clear Tag Stat

This menu item clears the Tag Write Cnt, Failed Tag Cnt, Tag Void Cnt, and Tag Read Cnt menu items.

Introduction to the RFID configuration options

Read Tag

Reads the tag in range of the internal RFID coupler and reports the tag data to the debug port and momentarily displays it on the control panel's LCD. It is mainly intended for data verification purposes.

IMPORTANT

This menu item does not position the RFID tag over the coupler. Make sure to position the tag over the coupler to receive an accurate reading.

Read Tag & Eject

IMPORTANT

This menu item does not position the RFID tag over the coupler. Make sure to position the tag over the coupler to receive an accurate reading.

The menu item works exactly the same as Read Tag (above), except that after the printer reads the tag, it feeds the label to the next top-of-form.

Comm Retry

Selects the number of automatic (internal) retries that the printer will attempt on the same tag before declaring a tag error and performing the Error Handling mode selected (Overstrike, Stop, or None).

The default value is 2.

Display F/W-Ver

Displays the reader firmware version on the control panel's LCD.

Overstrike Style

Selects the style of the overstrike pattern. The default is Grid.

For the **Grid** option, a grid pattern is printed during overstrikes. For the **Error Type Msg** option, an error message is printed to indicate which error occurred.

Introduction to the RFID configuration options

Table 4. Printed Overstrike Error Messages

Error Message	Explanation
Tag R/W Err x Check media	The printer software attempted to write to or read from the RFID tag, but the RFID encoder indicated that the tag could not be written to, or read from.
Tag Comm Err x Check cable	The printer software temporarily lost communication with the RFID encoder, or communication between the printer software and the RFID encoder was not synchronized and had to be forced.

NOTE: The x in the error messages represents a number code that identifies the area in the printer software or RFID encoder where the failure occurred.

Custom Setting

This menu item contains submenus that allow the RFID encoder to work with tag types that are not listed in the Tag Type menu item.

NOTE: SATO cannot guarantee the performance of tag types not certified by SATO.

Custom Setting Submenus

Custom Tag

This menu item enables or disables the Custom Setting submenus. The default is **Disable**.

When **Custom Tag** is set to **Disable**, the settings in the **Custom Setting** submenus are ignored by the RFID encoder.

When it is set to **Enable**, the RFID encoder uses the settings in the **Custom Setting** submenus, which must be set to match the characteristics of the custom tag.

When it is set to **Duplicate**, the settings of the selected **Tag Type** menu item are copied into the **Custom Setting** submenus, but are ignored by the RFID encoder.

Introduction to the RFID configuration options

Write Power

This menu item selects the write power level to be used in the RFID encoder. 1 is the lowest power level setting, and 20 is the highest. The default is 6.

Read Power

This menu item selects the read power level to be used in the RFID encoder. 1 is the lowest power level setting, and 20 is the highest. The default is 5.

EPC Byte Length

This menu item selects the number of bytes in the tag. The default is 12.

EPC Address

This menu item selects the starting location of the EPC block within the RFID tag memory. The default is 0.

USR Byte Length

This menu item selects the size of the USR block within the RFID tag memory. The default is 0.

USR Address

This menu item selects the starting location of the USR block within the RFID tag memory. The default is 0.

TID Byte Length

This menu item selects the size of the TID block within the RFID tag memory. The default is 8.

TID Address

This menu item selects the starting location of the TID block within the RFID tag memory. The default is 2.

Block Write Len

This menu item selects the maximum number of bytes written to the USR block within the RFID tag memory at one time. The default is 8.

Introduction to the RFID configuration options

Tag Class

Selects the class of the custom tag. Class 0+, Class 1.19, Gen 2, and Class Zuma tags are read/write. Class 0 tags are read only. The default is Gen 2.

Read Tries

Selects how many times the RFID encoder will try each read command. The default is infinite, which causes the encoder to try until the operation times out.

Write Tries

Selects how many times the RFID encoder will try each write command. The default is 9.

RFID Calibrate

Causes the printer to run calibration for the current RFID tags installed in the printer. After the calibration is complete, the custom settings are changed to work with the tags installed. These settings do not take effect until **Custom Tag** is set to **Enable**.

Tag Position

Determines how far the RFID tag position of the currently installed custom tags differs from the RFID tag position of the standard SATO tag. SATO printers print at maximum speed with RFID labels that have RFID tags in the standard position. The default is 0.0 mm.

Introduction to the RFID configuration options

Scan Start Pos

Determines where on the label the RFID calibration will begin. By default, the calibration procedure will start at the beginning of the label (0.0 mm). To speed this up change this value to force the calibration to begin after the beginning of the label.

Scan Length

Determines how much of the label will be scanned during the RFID calibration procedure. The default is 76mm.

Cal Min Power

Determines the minimum power level that the calibration procedure will use when attempting to find the ideal power level. To speed this up, increase the value to exclude the lower power levels. The default is 1.

Cal Max Power

Determines the maximum power level that the calibration procedure will use when attempting to find the ideal power level. To speed this up, decrease this value to exclude the higher power levels. The default is 20.

Introduction to the RFID configuration options

Requesting An RFID Report

This procedure prints a summarized RFID report. (This report also includes validator data if the printer has a validator.)

GL4xxe

1. Take the printer offline and press **ENTER** to enter **Menu** mode.
2. Press the **Down Arrow** and **ENTER** buttons at the same time until a message "THE ENTER KEY IS UNLOCKED" is displayed.
3. Press the **Right Arrow** key until **DIAGNOSTICS** displays.
4. Press **ENTER** to enter the **DIAGNOSTICS** menu. Make sure **Printer Tests** is selected.
5. Press the **Left Arrow** button until **RFID Report** displays.
6. Press **ENTER** to print the report.
7. Press the **Down** and **ENTER** buttons at the same time to lock the **ENTER** button, then press the **LINE** button to take the printer offline.
8. Press the **LINE** button again to take the printer online.

Introduction to the RFID configuration options

Advanced RFID Calibration

Tag Profiler

Read and Write power settings can be optimized using the Tag Profiler. Before running the Tag Profiler, it is important to ensure that the proper Gap Sensing procedure has been followed. It is recommended that you calibrate the printer to ensure that gap sensing settings are correct.

To use the Tag Profiler, first ensure that the tag type that you have selected from the Tag Type menu or page 3 [GL4xxe] for a list of supported tag types) either matches the tag type you are about to calibrate or is at least of the same Class and data length (i.e. 64 or 96 bits). Next, check that **Custom Tag** is set to Duplicate. The correct defaults will then be set for **Custom Tag Class** and **Tag (EPC Byte) Length**.

Before initiating the calibration cycle, the Tag Profiler can be optimized by setting appropriate limits on the following four custom entries:

- **Custom (Scan) Start Pos.** Identifies the starting position of the calibration scan. The default will start at the Top Of Form (TOF). To avoid inefficient scanning at points far away from the target tag, set the (Scan) Start Pos within one inch of the center of the physical tag. E.g., if the center of the tag is physically 76mm from the TOF, set (Scan) Start Pos to 51mm (25mm (1 inch) before the center of the tag).
- **Custom Scan Length.** This refers to the distance that the Tag Profiler will scan to determine the optimum tag position. For improved performance, set Custom Scan Length to 51mm or less. This will prevent the printer from looking for a tag far beyond its actual location.
- **Custom (Cal) Min Power.** Sets the lower level that will be tested during calibration. To speed up calibration, set Custom Min Power to two points lower than the Custom Read Power that was set prior to initiating calibration.

- **Custom (Cal) Max Power.** Sets the upper level that will be tested during calibration. To speed up calibration, set Custom (Cal) Max Power to two points higher than the Custom Write Power that was set prior to initiating calibration.

After setting the four custom entries, initiate the calibration cycle: access the **RFID Calibrate** menu and press **Enter**. The calibration will proceed using the first three good tags. A calibration progress indicator will update on the display. At the end of the calibration cycle, the Tag Profiler will update the Custom Write Power, Read Power, and Tag Position.

Custom Tag Configurator

When **Custom Tag** is set to **Duplicate**, you can manually edit all the custom entries. This allows you to overwrite the values discovered by the calibration in case you want to experiment further. It is generally best to accept the calibration values as is unless you are intimately familiar with the printer and its RFID processes.

Before you leave the Custom Tag Configurator, record the result from Custom Tag Position. This will be useful when deriving the optimum position for your tag with your converter. Tell the converter to move the tag from the current position by the amount in Custom Tag Position. A positive value means move toward TOF, a negative value means move away from TOF.

Auto Inlay Locator

After you have run the Tag Profiler (using Custom Run Cal or RFID Calibrate) and recorded the Custom Tag Position (offset from optimum position), you may now set Custom Tag to Enable in preparation to use the media with the Auto Inlay Locator.

When **Custom Tag** is set to **Enable**, the Auto Inlay Locator uses the results of the Tag Profiler calibration cycle to automatically advance the label to the correct encoding position, encode the tag with the correct write/read power, back-feed the label to the TOF, and proceed normally to print the full label without interruption.

2. RFID Command Specification

With the SATO GL4XXe, it is possible to return RFID information before writing data.

The printer supports Continuous, Tear-off, Dispenser and Cutter print mode options. Usually, writing information to the RFID supply takes about 3 seconds to complete. Any abnormality that interrupts the writing of information presented by RFID supply, takes about 5 seconds to show up as an error. However, process time still varies, depending on the data size of the write information. If reading and writing of RFID information fails due to defectiveness such as RFID supply, it takes about 10 seconds to present as an error. Keystrokes do not register when information writing is under progress.

EPC Code Write			ESC+IP0
Command	ESC	IP0	Parameter
Hex code	<1B>16	<49>16<50>16<30>16	e, d, k, a, u, m, f, p, s, t, c, n
Initial value	Nil		

Valid range and term of command	When power switch is OFF	The set command is not maintained.
	Valid range within item	The set parameter becomes invalid.
	Valid range between items	The set parameter becomes invalid.

[Function]

This is a control function for Writing data to Gen2 RFID tag.

[Format]

<IP0> e: x , d:xxxxxxxxxxxxxxxxxxxxxxxxxxx, k:xxxxxxx, a:xxxxxxx, p:xxxxxxx, u:x....x, m:xxxxx,f:x, p:xx, s:xx, c: xx, t:x, n:xxxxxxxxxxxx;

[Parameters]

e = [EPC Type]

a: EAN128 SSCC 96

c: EAN13 SGTIN 96

z: free mapping

d = [EPC Data]

24 digits if 'e' = z

17 digits if 'e' = a

13 digits if 'e' = c

Parameters when 'e' = Free mapping

k = [Kill code] (Max. Data Length is 8 bytes, Data should be Hex (0 to F))

a = [Present Access Code] (Max. Data Length is 8 bytes, Data should be Hex (0 to F))

p = [New Access Code] (Max. Data Length is 8 bytes Data should be Hex (0 to F))

u = [User Memory] (Max. Data Length depends on the tag manufacturer, Data should be Hex (0 to F))

m = [Locking of blocks] (5 digit Mask, 0: Unlock 1: Lock)

Block	Mask byte (digit from right)
EPC Area (d)	00001 (0)
Kill Code (k)	00010 (1)
Access code (a)	00100 (2)
TID Area	01000 (3)
User Memory (u)	10000 (4)

When e = "a" (EAN128 SSCC 96) or "c"(EAN13 SGTIN 96)

f = filter value (a value between 0 and 7)

s = total number of digits for serial reference (Should be any value with 5 to 11, a combination of s and c should be 17. Applicable only if EAN128 SSCC 96 is selected)

t = total number of digits for item reference (Should be any value with 1 to 7, a combination of s and c should be 13. Applicable only if EAN128 SSCC 96 is selected)

c = total number of digits for company prefix

(Should be any value with 6 to 12 according to the number of digits of 's' or 't' parameters)

n = serial Number (12digits)

(Should be any value with 12 digits, only applicable when EAN13 STGIN 96)

Coding Examples

【Example 1】

Description:

This example illustrates the method to write and lock EPC data of an unlocked tag and write access code to the blank access code area.

Data:

<A>

<V>50<H>50<X22>,AAAA01234567890123456789

<IP0>e:z,d:AAAA01234567890123456789,a:1111AAAA,m:00001;

<Q1>

<Z>

【Example 2】

Description:

This example illustrates to write to a locked tag with out changing the access code.

Data:

<A>

<V>50<H>50<X22>,BBBB01234567890123456789

<IP0>e:z,d:BBBB01234567890123456789,p:1111AAAA,m:00001;

<Q1>

<Z>

【Example 3】

Description:

This example illustrates to write to a locked tag and to write a new access code.

Data:

<A>

<V>50<H>50<X22>,CCCC01234567890123456789

<IP0>e:z,d:CCCC01234567890123456789,p:1111AAAA,a:2222BBBB,m:00001;

<Q1>

<Z>

【Example 4】

Description:

This example illustrates to write data to the user memory blank of the tag.

Data:

<A>

<V>50<H>50<X22>,USER_MEMORY_56CHAR

<IP0>e:z,u:01234567890123456789012345678901234567890123456789012345;

<Q1>

<Z>

【Example 5】

Description:

This example illustrates to write EAN 128 data to the tag.

Data:

```
<A>  
<V>50<H>50<X22>,3114F536CCCE4C3097000000  
<IP0>e:a,d:34017587461099671,f:0,s:10,c:7;  
<Q1>  
<Z>
```

Note:

The EAN 128 data will be encrypted as per EPC Generation 1 Tag Data Standards Version 1.1 Rev.1.27 (SSCC 96).

【Example 6】

Description:

This example illustrates to write EAN 13 data to the tag.

Data:

```
<A>  
<V>50<H>50<X22>,301803CB4F48B38000000001  
<IP0>e:c,d:4003885006606,f:0,t:7,c:6,n:000000000001;  
<Q1>  
<Z>
```

Note:

The EAN 128 data is encrypted as per EPC Generation 1 Tag Data Standards Version 1.1 Rev.1.27 (SGTIN 96).

【Notes】

1. If EPC code cannot be coded into the tag, printer will execute an error action according to the settings done from RFID mode.
2. Except “e”, which is imperative and in the fixed position (top), parameters can be omitted when not needed.
3. Multiple print designations are only possible if IP0 command is used in combination with other print data.
4. A word about access code, two parameters are used for access code (p: present access code and a: New access code to be encoded into the tag)
 - If ‘a’ parameter is used alone in an IP0 command, the data of ‘a’ parameter will be written in to the access code area of the tag.
 - If ‘p’ parameter is used alone in an IP0 command, the data of ‘p’ parameter will be used as a key to write other memory blanks of the tag. The access code area remains unchanged.
 - If both ‘a’ and ‘p’ parameters are used in an IP0 command, the data of ‘p’ parameter will be used as a key to write other memory blanks of the tag and data of ‘a’ parameter will be written in to the access code area of the tag.

5. The optional parameters could be omitted. Refer the table below to find optional parameters.

parameters		Gen2		
e:	EPC Type	[F***] _a (EAN128 SSCC96)	[F***] _c (EAN13 SGTIN96)	[F***] _z (free mapping)
d:	EPC Data	[F***]17 Digits	[F***]13 Digits	[F**]16、24 Digits
k:	Kill Code	x	x	[F**](8 digits)
a:	New Access Code	x	x	[F*](8 digits)
p:	Present access code	x	x	[F*](8 digits)
m:	Lock Mask	x	x	[F*](5 digits)
u:	User memory	x	x	[F**](1024 digits)
f:	filter value	[F***]0~7	[F***]0~7	x
s:	No of digits of serial reference	[F***]5~11 *1	x	x
t:	Item reference	x	[F***]1~7 *2	x
c:	company prefix	[F***]6~12 *1	[F***]6~12 *2	x
n:	Serial number	x	[F***]12digits	x

[F***] : Can not be omitted

[F**] : More than one is needed

[F*] : Could be omitted

: Can not be

x specified

*1 Combination of company prefix
and serial reference should be 17

*2 Combination of company prefix
and item reference should be 13

EPC Code Read			ESC+IP1
Command	ESC	IP1	Parameter
Hex code	<1B>16	<49>16<50>16<31>16	b
Initial value	Nil		

Valid range and term of command	When power switch is OFF	The set command is not maintained.
	Valid range within item	The set parameter becomes invalid.
	Valid range between items	The set parameter becomes invalid.

[Function]

This is a control function for reading data from the EPC code-compatible RFID tag.

[Format]

<IP1> ,b:X;

Where ,

b = Block Number

Block Name	Block No
EPC Area	1
TID Area	2
User	3

[Return Status Format]

[STX(02H)] + Data + [ETX(03H)]

Return status list

Item	Contents (Binary)	No. of bytes
STX(02H)	Start code	1 byte
Data	Data	Depends on tags and blocks
ETX(03H)	End code	1 byte

[Coding Example 1]

<A>

<IP1>,b:1;

<Z>

EPC Trade Mark Print		ESC+TM	
-----------------------------	--	---------------	--

Hexadecimal code	ESC <1B>16	TM <54>16<4D>16	Parameter X
Initial value	Nil		

Valid range and term of command	When power switch is OFF	The set parameter is not maintained.
	Valid range within item	The set parameter becomes invalid.
	Valid range between items	The set parameter becomes invalid.

[Function]

This is a Graphic function specifying the print of EPC trade mark on a tag label.

[Format]

<TM>X

[Parameters]

X=[Logo ID No.]

1:



2:



[Coding Example1]

<A>
<V>50<H>50<TM>1
<Z>

[Coding Example2]

<A>
<V>50<H>50<TM>2
<Z>



[Notes]

1. Rotation <%> and Enlargement <L> are also available.
2. Specify the command Enlargement <L> right before <TM> in case of its usage.
3. The original print area is,
W143XH101 dots for logo1
W202XH101 dots for logo2 (without the designation of enlargement)
4. When the parameter X is left blank, the logo 1 will be printed.

Sequential numbering			ESC+F
Hexadecimal code	ESC <1B>16	F <46>16	Parameter a a a a b c c c c, d d, e e, f
Initial value	Nil		
Valid range and term of command	When power switch is OFF	The set parameter is not maintained.	
	Valid range within item	The set parameter becomes invalid.	
	Valid range between items	The set parameter becomes invalid.	

[Function]

This is a control function to specify data to be sequentially incremented or decremented. In the data stream this command should be placed before EPC write command.

[Format]

<F> a a a a b c c c c (, dd, e e, f)

[Parameters]

- aaaa** Number of times to repeat the same data : 0001-9999
- b** Plus or minus symbol (+ for increments; - for decrements)
- cccc** Value of step for sequence (0001-9999)
- ,dd** Number of digits for sequential numbering (01-99), if these digits are left out, the default is 8.
- ,ee** Number of digits free from sequential numbering (00-99) starting with the rightmost position. If these digits are left out, the default is 0.
- f** Decimal or Hexadecimal : 0 = decimal
1 = Hexadecimal
When this digit is left out, the default is 0.

[Coding Example 1] Write EPC and Lock Tag

Number of times to repeat the same data : 1, incrementing :+, step of sequence:1,Number of digits for Sequential numbering: 5, Number of digits free from sequential numbering: 0

```

<A>
<V> 100<H>100<X21>, Sequential Test
<F>1+1,5,0<IP0> e:z,d:1122334455ABCDEF01234567,a:1111AAAA,m:00001;
<Q> 2
<Z>

```

[Coding Example 2] Write EPC and User memory

Number of times to repeat the same data : 1, incrementing :+, step of sequence:100,Number of digits for Sequential numbering: 3, Number of digits free from sequential numbering:2

```
<A>  
<V>100<H>100<P>2<L>0202  
<F>1+100,3,2,0<IP0>e:z,d:ABCDE1122334455ABCD056CC,u:ABC078CC;  
<Q>3  
<Z>
```

[Notes]

1. Up to Max. eight different sequential fields can be specified per label.
2. This command can not be used with the following commands.
Reverse Image command <(>
Line Feed command <E>
3. Among the RFID commands, only IP0 should be used in combination with this command. Only free mapping functionality of (EPC area and User Area) IP0 command is valid with this command.
4. If EPC area and user area is specified in the same IP0 command, the sequential functionality will be valid for both fields.

3. GL RFID Coupler Design

The GL4xxe RFID has a coupler design that supports a greater variety of tag types. You can move the coupler horizontally by using the coupler handle. See figures on following pages.

The coupler has four positions on a four inch printer.

Yellow: 1st Position (furthest inboard)

Orange: 2nd Position

Red: 3rd Position

Blue: 4th Position (furthest outboard on a 4 inch printer)

Once you select a tag type from the front panel, the following message will be displayed on the LCD:

Set Antenna Pos To x If Done Press Enter
--

Where **x** is the word Yellow, Orange, Red and Blue

4. Adjusting the Coupler position

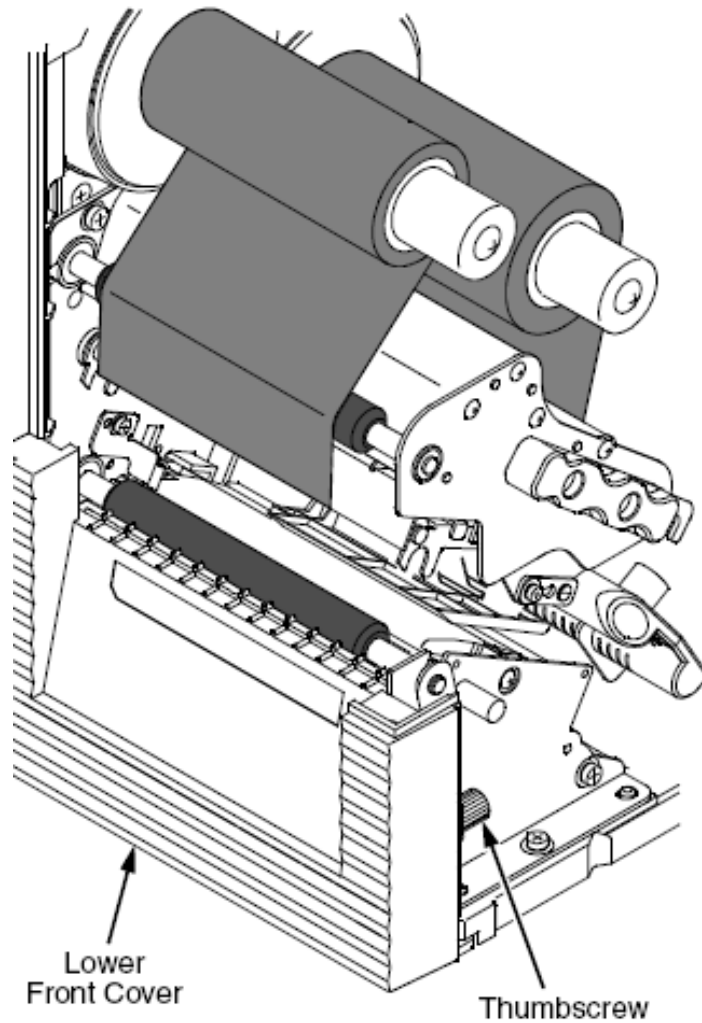

Remove the thumbscrew that secures the lower front cover to the printer. Slide the cover to the left (toward the electrical half of the printer) to remove it.

Adjusting the Coupler position

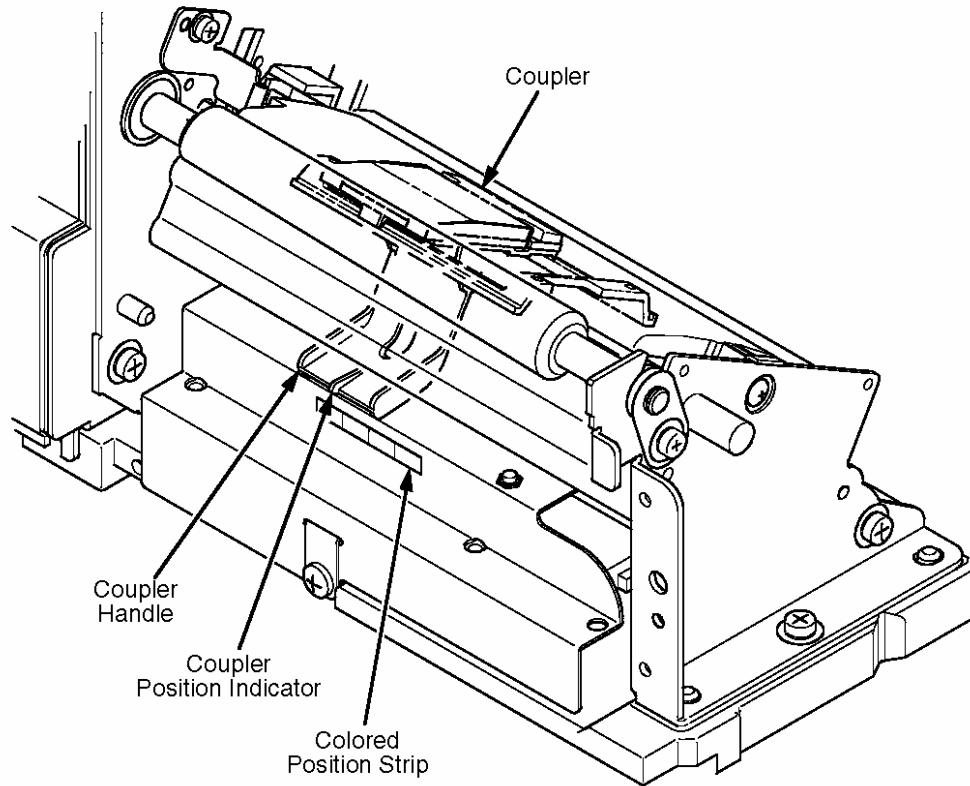

Use the coupler handle to adjust the coupler so that the coupler position indicator points to the correct color on the colored position strip.

Aligning the tabs, install the lower front cover (See **RFID Kit Installation Guide**) Step 2. Secure the lower front cover to the printer using the thumbscrew.

4. Error Messages

The RFID encoder can detect a number of errors. When one of these errors occurs, the RFID encoder alerts the printer to perform the currently selected error action

Error Message	Explanation	Solution
NON-RFID DATA On Rfid Tag	A job was printed that had no RFID commands on at least one form of the job while RFID tags were installed in the printer and the Non-RFID Warning menu item is set to Enable.	Press LINE to clear the message. Set Non-RFID Warning to Disable, print a job with RFID commands on every form, or install non-RFID labels in the printer
RFID Comm Err Check Cable	RFID error: communication cannot be established with the RFID encoder. Reader will be set to Disable in the RFID (or RFID CONTROL) menu and the previous port settings restored	Press LINE to clear the message.
RFID FW ERR: Version Mismatch	The RFID encoder firmware version is not capable of operating with the printer software.	Press LINE to clear the message. Re-download the program file to the printer.
RFID LOCK CMD: Not supported!	A lock command was executed on a tag which does not support locking. All Class 1 tags and most Gen 2 tags support locking. Other tag classes such as Class 0+, Class 1.19, and Class Zuma do not support locking.	Press LINE to clear the message. Remove the lock command from the application.
RFID MAX RETRY Check System	Error Handling = Overstrike in the RFID (or RFID CONTROL) menu, and the Label Retry count has been exhausted.	Press LINE to clear the message.
RFID TAG ERR: Read-Only Tag	A write was attempted on a read-only tag.	Press LINE to clear the message. Change media to writable tags or remove the write command from the application
RFID TAG FAILED Check Media	Error Handling = Stop in the RFID (or RFID CONTROL) menu, and the RFID encoder could not read the RFID tag.	Press LINE to clear the message.
RFID UNLOCK CMD: Not Supported!	An unlock command was executed on a tag which does not support locking.	Press LINE to clear the message. Remove the unlock command from the application.
RFID ACS FIELD: Not Supported	The ACS field was accessed on a tag which does not support the ACS field	Press LINE to clear the message. Remove references to the ACS field from the application
RFID KIL FIELD: Not Supported!	The KIL field was accessed on a tag which does not support the KIL field.	Press LINE to clear the message. Remove references to the KIL field from the application.

Troubleshooting

If you are having trouble with the RFID encoder, consult Table below for a list of symptoms and possible solutions.

Symptom	Solution
No communication between the printer and the reader	<ol style="list-style-type: none"> 1. Make sure Reader = Enable in the RFID (or RFID CONTROL) menu. 2. Use the RFID Test option in the RFID (or RFID CONTROL) menu (Admin User enabled) to read and display the current RFID tag content..
Tag failed	<ol style="list-style-type: none"> 1. The label could be misaligned. Perform the Auto Calibrate procedure to ensure the label is at top-of-form 2. Make sure the media are smart labels with RFID tags located in the correct position. 3. The RFID tag could be defective. Try another tag. 4. Make sure the application does not send too few or too many digits to the RFID tag.
Inconsistent results	Make sure the media is loaded correctly.
The RFID encoder works, but it does not meet expectations	Make sure that both Error Handling and Label Retry are set to desired values in the RFID (or RFID CONTROL) menu

